

ASCO™ Pneumatic Angle and Straight Seat Valves

2-way, Pressure Operated, Stainless Steel Body and Actuator

3/8" to 2 1/2" Tapped or with flanges (DIN EN 1092-1 and ANSI Class 150, DN15 to DN65)

2/2
Series
290

Features and Benefits

- Robust heavy duty AISI 316L stainless steel construction ensures valve is suitable for harsh environments
- Special design of the valve prevents external build up and is easy to clean
- All wetted parts are available for contact with food in compliance with the EC Directive 1935/2004 and FDA CFR21
- Exhaust air can be easily ducted to reduce emissions and protect the environment
- Specifications are laser marked on the valve to prevent loss during high pressure washing
- Ample fluid passage for optimal flow
- Adjustable actuator enables 360° access to pilot port
- Modular design provides exceptional flexibility
- Anti-water hammer design and back pressure resistant
- Extensive range of actuators, options, certifications and accessories

General

Differential pressure	See Specifications section [1 bar =100 kPa]
Vacuum	10 ⁻² mbar (10 ⁻² Torr/mm Hg)
Maximum allowable pressure	16 bar (240 psi)
	25 bar (360 psi) with P16 and HTP options
Ambient temperature range	-20°C to +70°C (-4°F to 158°F)
	WSF option -10°C to +70°C (14°F to 158°F)
	HTP option -10°C to +80°C (14°F to 176°F)
	LTP option -60°C to +65°C (-76°F to 149°F)
Nominal pressure	PN16 (32 mm actuator)
	PN25 (DN32 to DN65)
	PN40 (DN15 to DN25)
Maximum viscosity	800 cSt (mm ² /s) (2.700 SSU)
Pilot fluid	Filtered air or water
Maximum pilot pressure	10 bar (150 psi) / bistable function: 8 bar (120 psi)
Minimum pilot pressure	See Specifications section
Response time	See dedicated pilot catalog pages

Fluids (*)	Temperature range (TS) ⁽¹⁾	Disc seal (*)
DN10 to DN50: Air and gas groups 1 and 2	-20°C to +140°C (-4°F to 284°F)	PTFE (HTP: PTFE carbon)
DN 65: Air and gas group 2	WSF option: -10°C to +184°C (14°F to 360°F)	
All DN: Liquids groups 1 and 2 and steam	LTP option: -60°C to +65°C (-76°F to 149°F)	
	HTP option: -10°C to +220°C (14°F to 428°F)	

Materials of components in contact with fluid

(*) Ensure that compatibility of materials in contact with fluids is verified.

	Stainless steel	All 316L grade version with body passivation
Body	Stainless steel AISI 316L	Stainless steel AISI 316L
Stuffing box housing	Stainless steel AISI 316L	Stainless steel AISI 316L
Stem	Stainless steel AISI 431	Stainless steel AISI 316L
Disc	Stainless steel AISI 316L	Stainless steel AISI 316L
Disc seal	PTFE	PTFE
Wiper seal	PTFE	PTFE
Stuffing box packing	PTFE	PTFE
Valve body seal	PTFE	PTFE
	Angle seat valve	
Thread connection	3/8" to 2 1/2" (DN10 to DN65)	
	Straight seat valve	
Connection	Flanges PN40 (DN15 to DN25), PN 25 (DN32 to DN65) type 11 (ISO 7005 / EN 1092-1)	
	ANSI Class 150 ASME B16.5	
Face-to-face dimensions	EN 558-1	
Face de joint	Type B	
Other components		
Actuator	Stainless steel AISI 316L	
Optical position indicator	PA 12	

⁽¹⁾ The minimum ambient temperature of the valve is determined by the limitations of minimum temperature indicated.

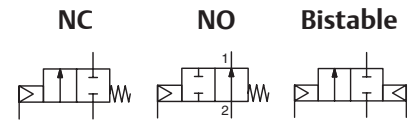

NC function, entry under the disc, 63 mm operator

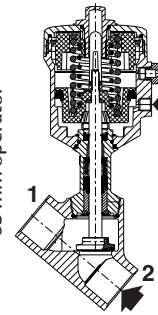

NO function, entry under the disc, 63 mm operator

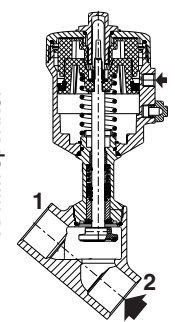

NC function, entry above the disc, 63 mm operator

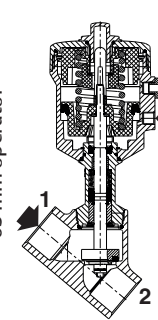

Bistable function, 63 mm operator

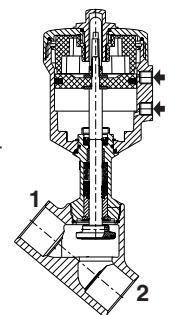

01534CB-2021/R01 Availability, design and specifications are subject to change without notice. All rights reserved.

Certifications and Approvals

- Pressure Equipment Directive 2014/68/EU
- Functional Safety of Machinery: EN ISO 13849-1
- Reach compliant
- IEC 61508 Standard (2010 route 2_H version) certified with integrity levels: SIL 2 for HFT = 0
- The valves satisfy all relevant EU and EAC directives
- RoHS compatible

Options ⁽¹⁾

- Oxygen service pressure limited to 15 bar (220 psi), media temperature limited to +60°C (140°F)
- Explosive atmospheres, ATEX and IECEx compliant
- Medium vacuum service up to 10⁻³ mb (10⁻³ Torr)
- EN 161/EN 16678 compliant versions (see dedicated catalog pages)
- Pilots (see dedicated catalog pages)
- Large range of switch boxes and digital positioners (see dedicated catalog pages)
- Valve body material composition certificate 3.1

⁽¹⁾ See Choice of options and accessories (page 13)

Specifications (angle seat valves)

Piping (ISO 6708)		Flow coefficient		Pilot pressure		Operating pressure differential			Actuator diameter	Dimensions / Type ⁽¹⁾	Catalog number				
Pipe size	DN					bar (psi)					Air, inert gas (*)	Water, oil, liquids (*)	Steam ≤ 140°C (≤ 284°F) (*)	Thread type	
						m ³ /h (gal/min)	(l/min)	Min.						Max.	(G*)
NC - Normally closed, entry under the disc															
3/8"	10	2.8 (3.2)	46	4.7 (75)	10 (150)	16 (240)	16 (240)	10 (150)	32	01	E290D01P0SA0000	8290D01Q0SA0000			
1/2"	15	4.1 (4.7)	68	4.7 (75)	10 (150)	10 (150)	10 (150)	10 (150)	32	01	E290D02P0SA0000	8290D02Q0SA0000			
		5.8 (6.7)	96	4.5 (70)	10 (150)	16 (240)	16 (240)	10 (150)	50	02	E290D02R0SA0000	8290D02S0SA0000			
				5.5 (80)	10 (150)	25 (360)	25 (360)	10 (150)	50	02	E290D02R0SP1600	8290D02S0SP1600			
				2.8 (45)		16 (240)	16 (240)	10 (150)	63	03	E290D02T0SA0000	8290D02U0SA0000			
		4.5 (70)	10 (150)	25 (360)	25 (360)	10 (150)	63	03	E290D02T0SP1600	8290D02U0SP1600					
3/4"	20	6.5 (7.5)	108	4.7 (75)	10 (150)	6 (90)	6 (90)	6 (90)	32	01	E290D03P0SA0000	8290D03Q0SA0000			
		10.7 (12.4)	178	4.5 (70)	10 (150)	10 (150)	10 (150)	10 (150)	50	02	E290D03R0SA0000	8290D03S0SA0000			
				5.5 (80)	10 (150)	14 (210)	14 (210)	10 (150)	50	02	E290D03R0SP1600	8290D03S0SP1600			
				4.5 (70)		16 (240)	16 (240)	10 (150)	63	03	E290D03T0SA0000	8290D03U0SA0000			
				2.8 (45)	10 (150)	12 (180)	12 (180)	10 (150)	63	03	E290D73T0SA0000	8290D73U0SA0000			
				4.5 (70)	10 (150)	20 (300)	20 (300)	10 (150)	63	03	E290D03T0SP1600	8290D03U0SP1600			

(*) Ensure that compatibility of materials in contact with fluids is verified.

⁽¹⁾ For dimensions, see drawing(s) for each construction type on the following page(s).

Specifications (angle seat valves)

Piping (ISO 6708)		Flow coefficient Kv (Cv) m³/h (gal/min) l/min		Pilot pressure bar (psi) Min. Max.		Operating pressure differential			Actuator diameter (mm)	Dimensions / Type ⁽¹⁾	Catalog number				
Pipe size	DN					bar (psi)					Air, inert gas (*)	Water, oil, liquids (*)	Steam ≤ 140°C (≤ 284°F) (*)	Thread type	
						(G*)	(NPTF)								
1"	25	15.5 (18)	258	4.5 (70)	10 (150)	6 (90)	6 (90)	6 (90)	50	02	E290D04R0SA0000	8290D04S0SA0000			
				5.5 (80)	10 (150)	9 (135)	9 (135)	9 (135)	50	02	E290D04R0SP1600	8290D04S0SP1600			
		17.7 (20.5)	295	4.5 (70)	10 (150)	10 (150)	10 (150)	10 (150)	63	03	E290D04T0SA0000	8290D04U0SA0000			
		17.8 (20.6)	296	4.5 (70)	10 (150)	16 (240)	16 (240)	10 (150)	90	04	E290D04X0SA0000	8290D04Y0SA0000			
		17.7 (20.5)	295	2.8 (45)	10 (150)	6 (90)	6 (90)	6 (90)	63	03	E290D74T0SA0000	8290D74U0SA0000			
		17.8 (20.6)	296	2.8 (45)	10 (150)	12 (180)	12 (180)	10 (150)	90	04	E290D74X0SA0000	8290D74Y0SA0000			
				4.5 (70)	10 (150)	25 (360)	25 (360)	10 (150)	90	04	E290D04X0SP1600	8290D04Y0SP1600			
		1 1/4"	32	25.2 (29.2)	420	4.5 (70)	10 (150)	6 (90)	6 (90)	6 (90)	63	03	E290D05T0SA0000	8290D05U0SA0000	
26.2 (30.4)	436			4.5 (70)	10 (150)	12 (180)	12 (180)	10 (150)	90	04	E290D05X0SA0000	8290D05Y0SA0000			
25.2 (29.2)	420			2.8 (45)	10 (150)	3 (45)	3 (45)	3 (45)	63	03	E290D75T0SA0000	8290D75U0SA0000			
26.2 (30.4)	436			2.8 (45)	10 (150)	7 (105)	7 (105)	7 (105)	90	04	E290D75X0SA0000	8290D75Y0SA0000			
1 1/2"	40	38.3 (44.4)	638	4.5 (70)	10 (150)	4 (60)	4 (60)	4 (60)	63	03	E290D06T0SA0000	8290D06U0SA0000			
		40.4 (46.9)	673	4.5 (70)	10 (150)	8 (120)	8 (120)	8 (120)	90	04	E290D06X0SA0000	8290D06Y0SA0000			
		40.4 (46.9)	673	2.8 (45)	10 (150)	4 (60)	4 (60)	4 (60)	90	04	E290D76X0SA0000	8290D76Y0SA0000			
2"	50	51.4 (59.7)	857	4.5 (70)	10 (150)	2.5 (40)	2.5 (40)	2.5 (40)	63	03	E290D07T0SA0000	8290D07U0SA0000			
		54.9 (63.7)	915	4.5 (70)	10 (150)	6 (90)	6 (90)	6 (90)	90	04	E290D07X0SA0000	8290D07Y0SA0000			
2 1/2"	65	94 (109)	1566	4.5 (70)	10 (150)	2 (30)	2 (30)	2 (30)	90	04	E290D08X0SA0000	8290D08Y0SA0000			
NO - Normally open, entry under the disc															
3/8"	10	2.8 (3.2)	46	IX (*)	10 (150)	16 (240)	16 (240)	10 (150)	32	01	E290D11P0SA0000	8290D11Q0SA0000			
1/2"	15	4.1 (4.7)	68	IX (*)	10 (150)	16 (240)	16 (240)	10 (150)	32	01	E290D12P0SA0000	8290D12Q0SA0000			
		5.8 (6.7)	96	I (*)	10 (150)	16 (240)	16 (240)	10 (150)	50	02	E290D12R0SA0000	8290D12S0SA0000			
II (*)	10 (150)			16 (240)	16 (240)	10 (150)	63	03	E290D12T0SA0000	8290D12U0SA0000					
3/4"	20	6.5 (7.5)	108	IX (*)	10 (150)	16 (240)	16 (240)	10 (150)	32	01	E290D13P0SA0000	8290D13Q0SA0000			
		10.7 (12.4)	178	I (*)	10 (150)	16 (240)	16 (240)	10 (150)	50	02	E290D13R0SA0000	8290D13S0SA0000			
				II (*)	10 (150)	16 (240)	16 (240)	10 (150)	63	03	E290D13T0SA0000	8290D13U0SA0000			

(*) Ensure that compatibility of materials in contact with fluids is verified.
 (*) Minimum pilot pressure varies with differential pressure, see page 12
 (1) For dimensions, see drawing(s) for each construction type on the following page(s).

01534GB-2021/R01 Availability, design and specifications are subject to change without notice. All rights reserved.

Specifications (angle seat valves)

Piping (ISO 6708)		Flow coefficient Kv (Cv)		Pilot pressure bar (psi)		Operating pressure differential			Actuator diameter / Dimensions / Type ⁽¹⁾		Catalog number				
Pipe size	DN					bar (psi)							Air, inert gas (*)	Water, oil, liquids (*)	Steam ≤ 140°C (≤ 284°F) (*)
						m³/h (gal/min)	(l/min)	Min.			Max.	(G*)			
1"	25	15.5 (18)	258	I(*)	10 (150)	16 (240)	16 (240)	10 (150)	50	02	E290D14R0SA0000	8290D14S0SA0000			
		17.7 (20.5)	295	II(*)		16 (240)	16 (240)	10 (150)	63	03	E290D14T0SA0000	8290D14U0SA0000			
		17.8 (20.6)	296	III(*)		16 (240)	16 (240)	10 (150)	90	04	E290D14X0SA0000	8290D14Y0SA0000			
1 1/4"	32	25.2 (29.2)	420	II(*)	10 (150)	16 (240)	16 (240)	10 (150)	63	03	E290D15T0SA0000	8290D15U0SA0000			
		26.2 (30.4)	436	III(*)		16 (240)	16 (240)	10 (150)	90	04	E290D15X0SA0000	8290D15Y0SA0000			
1 1/2"	40	38.3 (44.4)	638	II(*)	10 (150)	11 (165)	11 (165)	10 (150)	63	03	E290D16T0SA0000	8290D16U0SA0000			
		40.4 (46.9)	673	III(*)		16 (240)	16 (240)	10 (150)	90	04	E290D16X0SA0000	8290D16Y0SA0000			
2"	50	51.4 (59.7)	857	II(*)	10 (150)	7 (105)	7 (105)	7 (105)	63	03	E290D17T0SA0000	8290D17U0SA0000			
		54.9 (63.7)	915	III(*)		13 (200)	13 (200)	10 (150)	90	04	E290D17X0SA0000	8290D17Y0SA0000			
2 1/2"	65	94 (109)	1566	III(*)	10 (150)	7 (105)	7 (105)	7 (105)	90	04	E290D18X0SA0000	8290D18Y0SA0000			
NC - Normally closed, entry above the disc (version recommended for rapid-cycling steam applications)															
3/8"	10	2.8 (3.2)	46	X(*)	10 (150)	10 (150)	-	10 (150)	32	01	E290D31P0SA0000	8290D31Q0SA0000			
1/2"	15	4.1 (4.7)	68	X(*)	10 (150)	10 (150)	-	10 (150)	32	01	E290D32P0SA0000	8290D32Q0SA0000			
		5.1 (5.9)	85	V(*)	10 (150)	10 (150)	-	10 (150)	50	02	E290D32R0SA0000	8290D32S0SA0000			
		6.1 (7.1)	101	VI(*)	10 (150)	10 (150)	-	10 (150)	63	03	E290D32T0SA0000	8290D32U0SA0000			
3/4"	20	6.5 (7.5)	108	X(*)	10 (150)	10 (150)	-	10 (150)	32	01	E290D33P0SA0000	8290D33Q0SA0000			
		10.3 (11.9)	171	V(*)	10 (150)	10 (150)	-	10 (150)	50	02	E290D33R0SA0000	8290D33S0SA0000			
		11 (12.8)	183	VI(*)	10 (150)	10 (150)	-	10 (150)	63	03	E290D33T0SA0000	8290D33U0SA0000			
1"	25	14.6 (16.9)	243	V(*)	10 (150)	10 (150)	-	10 (150)	50	02	E290D34R0SA0000	8290D34S0SA0000			
		18.4 (21.3)	306	VI(*)	10 (150)	10 (150)	-	10 (150)	63	03	E290D34T0SA0000	8290D34U0SA0000			
1 1/4"	32	30.7 (35.6)	511	VI(*)	10 (150)	10 (150)	-	10 (150)	63	03	E290D35T0SA0000	8290D35U0SA0000			
		31 (36)	516	VII(*)	10 (150)	10 (150)	-	10 (150)	90	04	E290D35X0SA0000	8290D35Y0SA0000			
1 1/2"	40	43.9 (50.9)	731	VI(*)	10 (150)	10 (150)	-	10 (150)	63	03	E290D36T0SA0000	8290D36U0SA0000			
		45 (52.2)	750	VII(*)	10 (150)	10 (150)	-	10 (150)	90	04	E290D36X0SA0000	8290D36Y0SA0000			
2"	50	58 (67.3)	966	VI(*)	10 (150)	9 (135)	-	9 (135)	63	03	E290D37T0SA0000	8290D37U0SA0000			
		59 (68.4)	983	VII(*)	10 (150)	10 (150)	-	10 (150)	90	04	E290D37X0SA0000	8290D37Y0SA0000			
2 1/2"	65	94 (109)	1566	VII(*)	10 (150)	10 (150)	-	10 (150)	90	04	E290D38X0SA0000	8290D38Y0SA0000			

(*) Ensure that compatibility of materials in contact with fluids is verified.
 (*) Minimum pilot pressure varies with differential pressure, see page 12
 (1) For dimensions, see drawing(s) for each construction type on the following page(s).

Specifications (angle seat valves)

Piping (ISO 6708)		Flow coefficient Kv (Cv) m ³ /h (gal/min) (l/min)		Pilot pressure bar (psi) Min. Max.		Operating pressure differential			Actuator diameter (mm)	Dimensions / Type (1)	Catalog number				
Pipe size	DN					bar (psi)					Air, inert gas (*)	Water, oil, liquids (*)	Steam ≤ 140°C (≤ 284°F) (*)	Thread type	
						Air, inert gas (*)	Water, oil, liquids (*)	Steam ≤ 140°C (≤ 284°F) (*)						(G*)	(NPTF)
Bistable function (version recommended for high fast cycling)															
3/8"	10	2.8 (3.2)	46	XII (*)	8 (120)	10 (150)	10 (150)	-	32	01	E290D41P0SA0000	8290D41Q0SA0000			
1/2"	15	4.1 (4.7)	68	XII (*)	8 (120)	10 (150)	10 (150)	-	32	01	E290D42P0SA0000	8290D42Q0SA0000			
		5.8 (6.7)	96	X (*)	8 (120)	10 (150)	10 (150)	-	50	02	E290D42R0SA0000	8290D42S0SA0000			
		5.8 (6.7)	96	XI (*)	8 (120)	10 (150)	10 (150)	-	63	03	E290D42T0SA0000	8290D42U0SA0000			
		6.5 (7.5)	108	XII (*)	8 (120)	10 (150)	10 (150)	-	32	01	E290D43P0SA0000	8290D43Q0SA0000			
3/4"	20	10.7 (12.4)	178	X (*)	8 (120)	10 (150)	10 (150)	-	50	02	E290D43R0SA0000	8290D43S0SA0000			
		10.7 (12.4)	178	XI (*)	8 (120)	10 (150)	10 (150)	-	63	03	E290D43T0SA0000	8290D43U0SA0000			
		15.5 (18)	258	X (*)	8 (120)	10 (150)	10 (150)	-	50	02	E290D44R0SA0000	8290D44S0SA0000			
1"	25	17.7 (20.5)	295	XI (*)	8 (120)	10 (150)	10 (150)	-	63	03	E290D44T0SA0000	8290D44U0SA0000			

Specifications (straight seat valves)

Piping (ISO 6708)		Flow coefficient Kv (Cv) m ³ /h (gal/min) (l/min)		Pilot pressure bar (psi) Min. Max.		Operating pressure differential			Actuator diameter (mm)	Dimensions / Type (1)	Catalog number				
Pipe size	DN					bar (psi)					Air, inert gas (*)	Water, oil, liquids (*)	Steam ≤ 140°C (≤ 284°F) (*)	Flange type	
						Air, inert gas (*)	Water, oil, liquids (*)	Steam ≤ 140°C (≤ 284°F) (*)						DIN EN 1092-1	ANSI 150 ASME B16.5
NC - Normally closed, entry under the disc															
1/2"	15	4.4 (5.1)	73	4.5 (70)	10 (150)	16 (240)	16 (240)	10 (150)	50	02	T290D02RDSA0000	T290D02SPSA0000			
				5.5 (80)	10 (150)	25 (360)	25 (360)	10 (150)	50	02	T290D02RDSP1600	T290D02SPSP1600			
				2.8 (45)	10 (150)	16 (240)	16 (240)	10 (150)	63	03	T290D02TDSA0000	T290D02UPSA0000			
				4.5 (70)	10 (150)	25 (360)	25 (360)	10 (150)	63	03	T290D02TDSP1600	T290D02UPSP1600			
3/4"	20	7.2 (8.3)	120	4.5 (70)	10 (150)	10 (150)	10 (150)	10 (150)	50	02	T290D03RDSA0000	T290D03SPSA0000			
				5.5 (80)	10 (150)	14 (210)	14 (210)	10 (150)	50	02	T290D03RDSP1600	T290D03SPSP1600			
				4.5 (70)	10 (150)	16 (240)	16 (240)	10 (150)	63	03	T290D03TDSA0000	T290D03UPSA0000			
	7.2 (8.3)	120	2.8 (45)	10 (150)	12 (180)	12 (180)	10 (150)	63	03	T290D73TDSA0000	T290D73UPSA0000				
			4.5 (70)	10 (150)	20 (300)	20 (300)	10 (150)	63	03	T290D03TDSP1600	T290D03UPSP1600				

(*) Ensure that compatibility of materials in contact with fluids is verified.
 (*) Minimum pilot pressure varies with differential pressure, see page 12
 (1) For dimensions, see drawing(s) for each construction type on the following page(s).

01534GB-2021/R01 Availability, design and specifications are subject to change without notice. All rights reserved.

Specifications (straight seat valves)

Piping (ISO 6708)		Flow coefficient Kv (Cv)		Pilot pressure bar (psi)		Operating pressure differential			Actuator diameter / Dimensions / Type ⁽¹⁾	Catalog number				
Pipe size	DN					bar (psi)						Air, inert gas (*)	Water, oil, liquids (*)	Steam ≤ 140°C (≤ 284°F) (*)
						m³/h (gal/min)	(l/min)	Min.		Max.	DIN EN 1092-1			
1"	25	11.2 (12.9)	186	4.5 (70)	10 (150)	6 (90)	6 (90)	6 (90)	50	02	T290D04RDSA0000	T290D04SPSA0000		
		12.1 (14)	201	4.5 (70)	10 (150)	10 (150)	10 (150)	10 (150)	63	03	T290D04TDSA0000	T290D04UPSA0000		
		12.9 (14.9)	215	4.5 (70)	10 (150)	16 (240)	16 (240)	10 (150)	90	04	T290D04XDSA0000	T290D04YPSA0000		
		12.1 (14)	201	2.8 (45)	10 (150)	6 (90)	6 (90)	6 (90)	63	03	T290D74TDSA0000	T290D74UPSA0000		
		12.9 (14.9)	215	2.8 (45)	10 (150)	12 (180)	12 (180)	10 (150)	90	04	T290D74XDSA0000	T290D74YPSA0000		
				4.5 (70)	25 (360)	25 (360)	10 (150)	90	04	T290D04XDSP1600	T290D04YPSP1600			
1 1/4"	32	19 (22)	316	4.5 (70)	10 (150)	6 (90)	6 (90)	6 (90)	63	03	T290D05TDSA0000	T290D05UPSA0000		
		19.4 (22.5)	323	4.5 (70)	10 (150)	12 (180)	12 (180)	10 (150)	90	04	T290D05XDSA0000	T290D05YPSA0000		
		19 (22)	316	2.8 (45)	10 (150)	3 (45)	3 (45)	3 (45)	63	03	T290D75TDSA0000	T290D75UPSA0000		
		19.4 (22.5)	323	2.8 (45)	10 (150)	7 (105)	7 (105)	7 (105)	90	04	T290D75XDSA0000	T290D75YPSA0000		
1 1/2"	40	27.3 (31.6)	455	4.5 (70)	10 (150)	4 (60)	4 (60)	4 (60)	63	03	T290D06TDSA0000	T290D06UPSA0000		
		27.4 (31.7)	456	4.5 (70)	10 (150)	8 (120)	8 (120)	8 (120)	90	04	T290D06XDSA0000	T290D06YPSA0000		
		27.4 (31.7)	456	2.8 (45)	10 (150)	4 (60)	4 (60)	4 (60)	90	04	T290D76XDSA0000	T290D76YPSA0000		
2"	50	39.7 (46)	661	4.5 (70)	10 (150)	2.5 (40)	2.5 (40)	2.5 (40)	63	03	T290D07TDSA0000	T290D07UPSA0000		
		40.8 (47.3)	680	4.5 (70)	10 (150)	6 (90)	6 (90)	6 (90)	90	04	T290D07XDSA0000	T290D07YPSA0000		
2 1/2"	65	65.4 (75.8)	1090	4.5 (70)	10 (150)	2 (30)	2 (30)	2 (30)	90	04	T290D08XDSA0000	T290D08YPSA0000		
NO - Normally open, entry under the disc														
1/2"	15	4.4 (5.1)	73	I(*)	10 (150)	16 (240)	16 (240)	10 (150)	50	02	T290D12RDSA0000	T290D12SPSA0000		
		4.4 (5.1)	73	II(*)		16 (240)	16 (240)	10 (150)	63	03	T290D12TDSA0000	T290D12UPSA0000		
3/4"	20	7.2 (8.3)	120	I(*)	10 (150)	16 (240)	16 (240)	10 (150)	50	02	T290D13RDSA0000	T290D13SPSA0000		
		7.2 (8.3)	120	II(*)		16 (240)	16 (240)	10 (150)	63	03	T290D13TDSA0000	T290D13UPSA0000		
1"	25	11.2 (12.9)	186	I(*)	10 (150)	16 (240)	16 (240)	10 (150)	50	02	T290D14RDSA0000	T290D14SPSA0000		
		12.1 (14)	201	II(*)		16 (240)	16 (240)	10 (150)	63	03	T290D14TDSA0000	T290D14UPSA0000		
		12.9 (14.9)	215	III(*)		16 (240)	16 (240)	10 (150)	90	04	T290D14XDSA0000	T290D14YPSA0000		
1 1/4"	32	19 (22)	316	II(*)	10 (150)	16 (240)	16 (240)	10 (150)	63	03	T290D15TDSA0000	T290D15UPSA0000		
		19.4 (22.5)	323	III(*)		16 (240)	16 (240)	10 (150)	90	04	T290D15XDSA0000	T290D15YPSA0000		

(*) Ensure that compatibility of materials in contact with fluids is verified.
 (*) Minimum pilot pressure varies with differential pressure, see page 12
 (1) For dimensions, see drawing(s) for each construction type on the following page(s).

Specifications (straight seat valves)

Piping (ISO 6708)		Flow coefficient Kv (Cv)		Pilot pressure bar (psi)		Operating pressure differential			Actuator diameter (mm)	Dimensions / Type (1)	Catalog number				
Pipe size	DN					bar (psi)					Air, inert gas (*)	Water, oil, liquids (*)	Steam ≤ 140°C (≤ 284°F) (*)	Flange type	
						m³/h (gal/min)	l/min	Min.						Max.	DIN EN 1092-1
1 1/2"	40	27.3 (31.6)	455	II (*)	10 (150)	11 (165)	11 (165)	10 (150)	63	03	T290D16TDSA0000	T290D16UPSA0000			
		27.4 (31.7)	456	III (*)	10 (150)	16 (240)	16 (240)	10 (150)	90	04	T290D16XDSA0000	T290D16YPSA0000			
2"	50	39.7 (46)	661	II (*)	10 (150)	7 (105)	7 (105)	7 (105)	63	03	T290D17TDSA0000	T290D17UPSA0000			
		40.8 (47.3)	680	III (*)	10 (150)	13 (200)	13 (200)	10 (150)	90	04	T290D17XDSA0000	T290D17YPSA0000			
2 1/2"	65	65.4 (75.8)	1090	III (*)	10 (150)	7 (105)	7 (105)	7 (105)	90	04	T290D18XDSA0000	T290D18YPSA0000			
NC - Normally closed, entry above the disc (version recommended for rapid-cycling steam applications)															
1/2"	15	3.8 (4.4)	63	V (*)	10 (150)	10 (150)	-	10 (150)	50	01	T290D32RDSA0000	T290D32SPSA0000			
				VI (*)		10 (150)	-	10 (150)	63	02	T290D32TDSA0000	T290D32UPSA0000			
3/4"	20	7.4 (8.5)	123	V (*)	10 (150)	10 (150)	-	10 (150)	50	01	T290D33RDSA0000	T290D33SPSA0000			
				VI (*)		10 (150)	-	10 (150)	63	02	T290D33TDSA0000	T290D33UPSA0000			
1"	25	11.3 (13.1)	188	V (*)	10 (150)	10 (150)	-	10 (150)	50	01	T290D34RDSA0000	T290D34SPSA0000			
		13.1 (15.1)	218	VI (*)		10 (150)	-	10 (150)	63	02	T290D34TDSA0000	T290D34UPSA0000			
1 1/4"	32	19.7 (22.8)	328	VI (*)	10 (150)	10 (150)	-	10 (150)	63	02	T290D35TDSA0000	T290D35UPSA0000			
		20.9 (24.2)	348	VII (*)		10 (150)	-	10 (150)	90	03	T290D35XDSA0000	T290D35YPSA0000			
1 1/2"	40	26.8 (31)	446	VI (*)	10 (150)	10 (150)	-	10 (150)	63	02	T290D36TDSA0000	T290D36UPSA0000			
		28.6 (33.1)	476	VII (*)		10 (150)	-	10 (150)	90	03	T290D36XDSA0000	T290D36YPSA0000			
2"	50	40.3 (46.7)	671	VI (*)	10 (150)	9 (135)	-	9 (135)	63	02	T290D37TDSA0000	T290D37UPSA0000			
		41.8 (48.4)	696	VII (*)		10 (150)	-	10 (150)	90	03	T290D37XDSA0000	T290D37YPSA0000			
2 1/2"	65	66.8 (77.4)	1113	VII (*)	10 (150)	10 (150)	-	10 (150)	90	03	T290D38XDSA0000	T290D38YPSA0000			

(*) Ensure that compatibility of materials in contact with fluids is verified.

(*) Minimum pilot pressure varies with differential pressure, see page: 12

(1) For dimensions, see drawing(s) for each construction type on the following page(s).

01534GB-2021/R01 Availability, design and specifications are subject to change without notice. All rights reserved.

Product selection guide

Configurator - CAD Files

PRODUCT CODE
E 290 D 0 3 T 0 S A00 00

Connection type

- E = ISO 228/1 & ISO 7/1
(combination thread, G*)
- 8 = NPTF (ANSI B 1.20.3)
- T = Flange
- J = ISO 7/1 «RC»

Product series
290

Revision letter

- D = Initial release

Function

- 0 = Normally Closed
- 1 = Normally Open
- 7 = Normally Closed - Low pilot pressure
- 3 = Normally Closed - Above the disc
- 4 = Double Acting (bistable)
- P = Normally closed with profil disc

Nominal diameter

- 1 = DN10 - 3/8"
- 2 = DN15 - 1/2"
- 3 = DN20 - 3/4"
- 4 = DN25 - 1"
- 5 = DN32 - 1 1/4"
- 6 = DN40 - 1 1/2"
- 7 = DN50 - 2"
- 8 = DN65 - 2 1/2"

Actuator diameter - Piloting connections

- P = 32 mm stainless steel - G 1/8"
- Q = 32 mm stainless steel - NPT 1/8"
- R = 50 mm stainless steel - G 1/8"
- S = 50 mm stainless steel - NPT 1/8"
- T = 63 mm stainless steel - G 1/8"
- U = 63 mm stainless steel - NPT 1/8"
- X = 90 mm stainless steel - G 1/4"
- Y = 90 mm stainless steel - NPT 1/4"
- G = 50 mm stainless steel - NAMUR plate⁽³⁾
- W = 63 mm stainless steel - NAMUR plate⁽³⁾
- Z = 90 mm stainless steel - NAMUR plate⁽³⁾

⁽³⁾ Solenoid pilot valves, series 551, 3/2 NC:

- Aluminum body, catalog number **SCG551A001**
- AISI 316L stainless steel body, catalog number **SCG551A40**

Options

- A00 = Without
- PFB = Prepared for signaling box mounting⁽¹⁾
- WOB = Without body⁽¹⁾
- AT1 = ATEX/IECEx 1/21 zones⁽¹⁾
- AT0 = ATEX/IECEx 0/20 zones⁽¹⁾
- 02S = Oxygen service 15 bar / 60°C
- HTP = Saturated steam up to 220°C
- LTP = Low temperature down to -60°C
- 12S = CUTR certification (EAC Ex 1/21 zones) for Product
- STL = Stroke limiter for opening⁽¹⁾
- TC6 = Test tightness class VI⁽¹⁾
- VAC = Industrial vacuum 10⁻³ mbar⁽¹⁾
- M31 = Stainless steel valve body material certificate 3.1⁽¹⁾
- FB0 = EC 1935-2004 and FDA CFR 21 material
- FEM = Fugitive emission class BH according to ISO 15848-1
- 327 = Adapter kit for pilot 327
- WSP = PTFE wiper seal
- WSF = FPM piston seal and steam using up to +184°C / 360°F
- P16 = PS > 16 bar (240 psi)

Valve body material

- S = Stainless steel body
- Y = All 316L

Port type 1-2

- 0 = Threaded port
- D = Flange DIN EN 1092-1 (ISO 7005) standard (2-way)
- P = Flange ANSI standard 150 (2-way)

⁽¹⁾ See "Choice of options and accessories", pages 13 and 14

Repair Kits and Service Parts

Angle seat valve

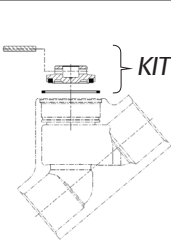
	Ø	DN	Spare parts kits no. 50-63-90 mm	
			entry under the disc	
			Normally Closed	Normally Open + Double Acting (bistable)
	1/2"	15	M29054935100800	M29054935103500
	3/4"	20	M29054935100900	M29054935103600
	1"	25	M29054935101000	M29054935103700
	1 1/4"	32	M29054935101100	M29054935105200
	1 1/2"	40	M29054935101200	M29054935105300
	2"	50	M29054935101300	M29054935105400
	2 1/2"	65	M29054935101400	M29054935105500

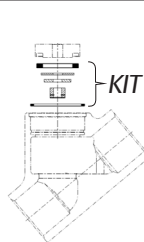
	Ø	DN	Spare parts kits no. 50-63-90 mm
			entry above the disc
	1/2"	15	M29054935100100
	3/4"	20	M29054935100200
	1"	25	M29054935100300
	1 1/4"	32	M29054935100400
	1 1/2"	40	M29054935100500
	2"	50	M29054935100600
	2 1/2"	65	M29054935100700

Straight seat valve

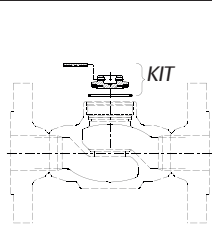
	Ø	DN	Spare parts kits no. 50-63-90 mm	
			entry under the disc	
			Normally Closed	Normally Open
	1/2"	15	M29054935100800	M29054935103500
	3/4"	20	M29054935100900	M29054935103600
	1"	25	M29054935101000	M29054935103700
	1 1/4"	32	M29054935101100	M29054935105200
	1 1/2"	40	M29054935101200	M29054935105300
	2"	50	M29054935101300	M29054935105400
	2 1/2"	65	M29054935101400	M29054935105500

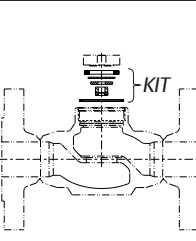
	Ø	DN	Spare parts kits no. 50-63-90 mm
			entry above the disc
	1/2"	15	M29054935100100
	3/4"	20	M29054935100200
	1"	25	M29054935100300
	1 1/4"	32	M29054935100400
	1 1/2"	40	M29054935100500
	2"	50	M29054935100600
	2 1/2"	65	M29054935100700

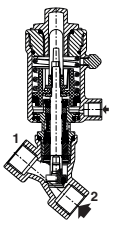
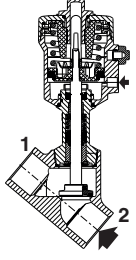
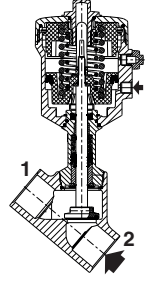
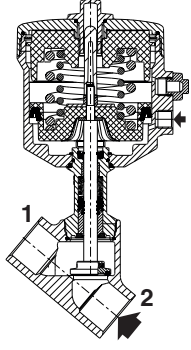
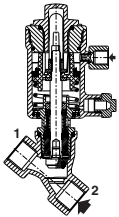
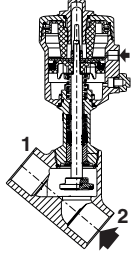
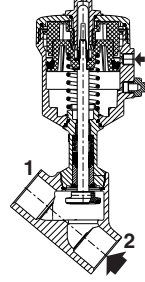
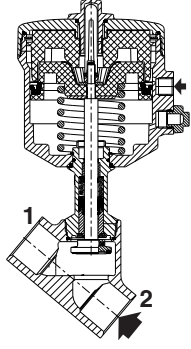
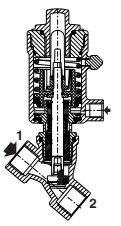
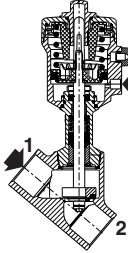
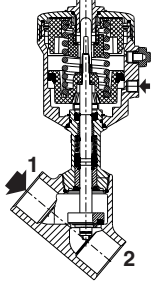
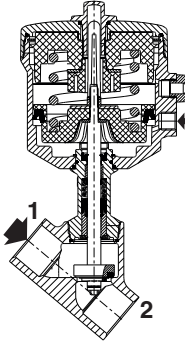
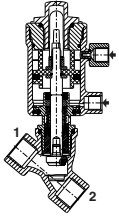
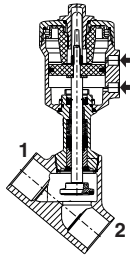
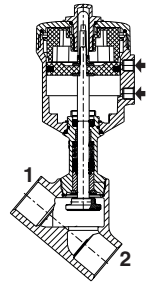
Angle seat valve - View showing the function / actuator / flow direction			
32 mm actuator	50 mm actuator	63 mm actuator	90 mm actuator
NC - Normally closed, entry under the disc			
			
NO - Normally open, entry under the disc			
			
NC - Normally closed, entry above the disc			
			
Bistable function			
			-

01534GB-2021/R01
Availability, design and specifications are subject to change without notice. All rights reserved.

Straight seat valve - View showing the function / actuator / flow direction

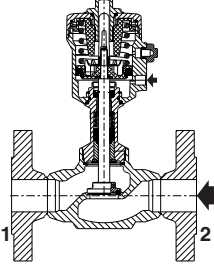
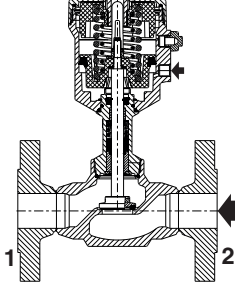
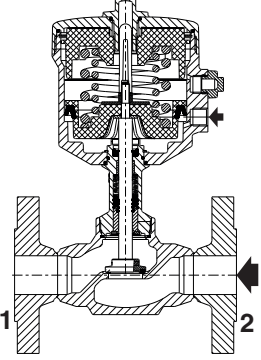
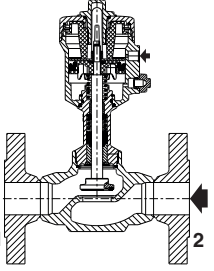
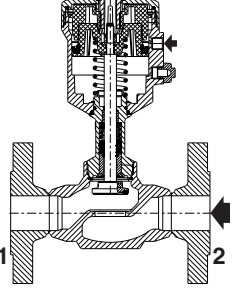
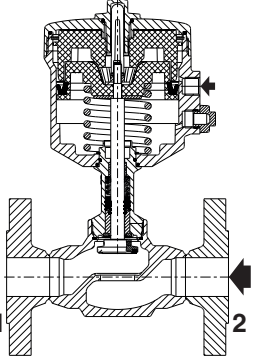
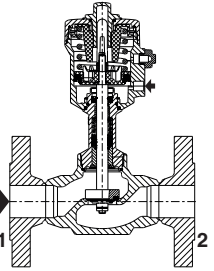
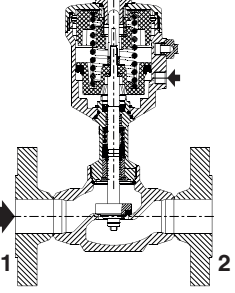
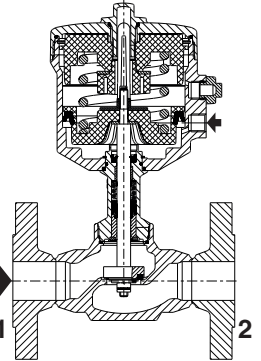
50 mm actuator	63 mm actuator	90 mm actuator
NC - Normally closed, entry under the disc		
		
NO - Normally open, entry under the disc		
		
NC - Normally closed, entry above the disc		
		

01534GB-2021/R01
Availability, design and specifications are subject to change without notice. All rights reserved.

Selection of the minimum pilot pressure

NO - Normally open, entry under the disc

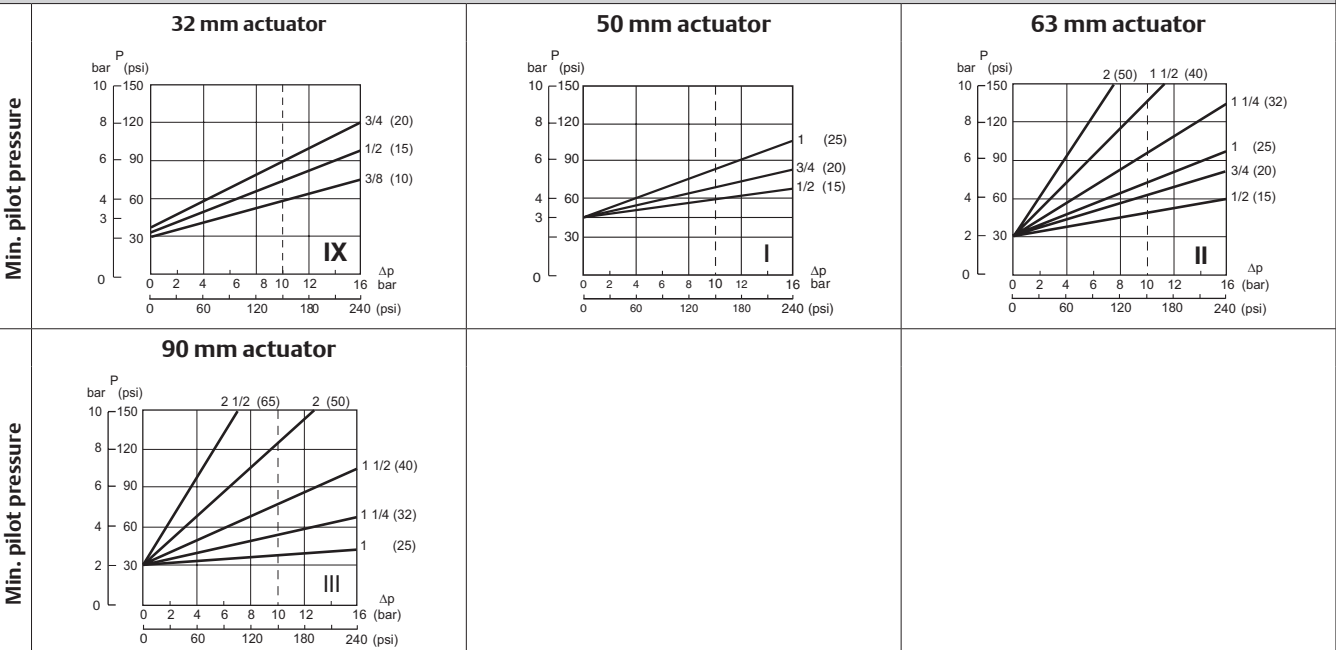

NC - Normally closed, entry above the disc

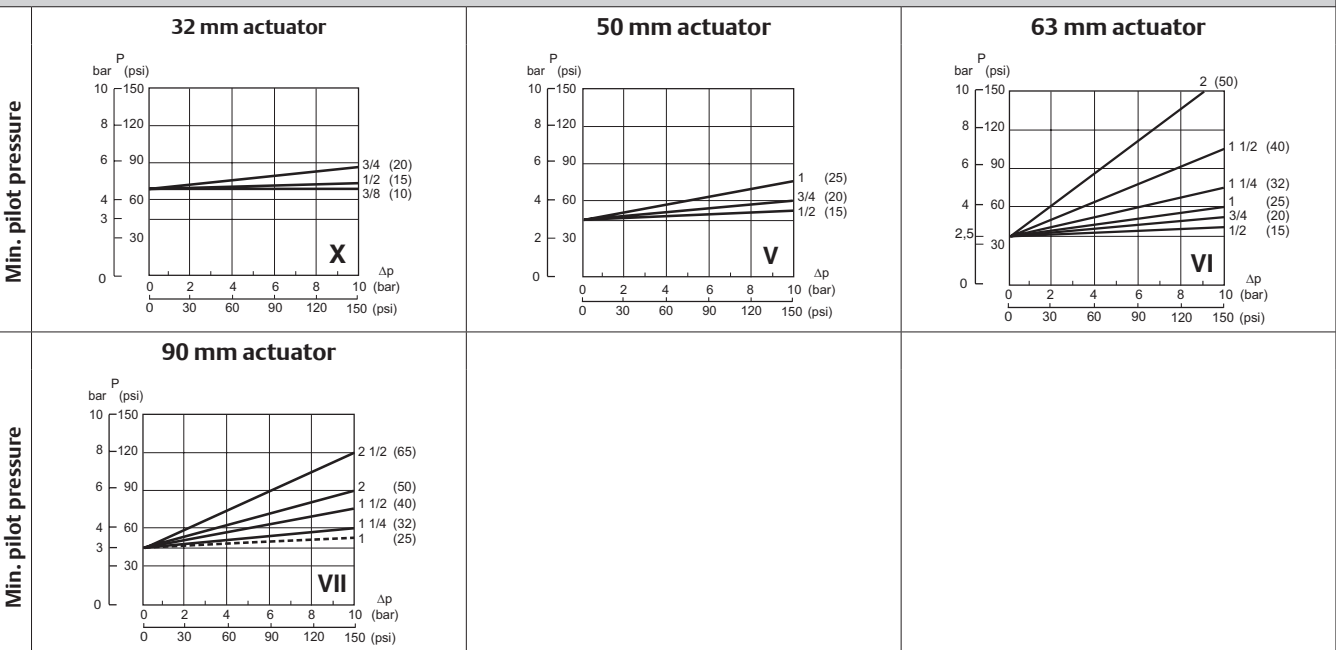

Bistable function

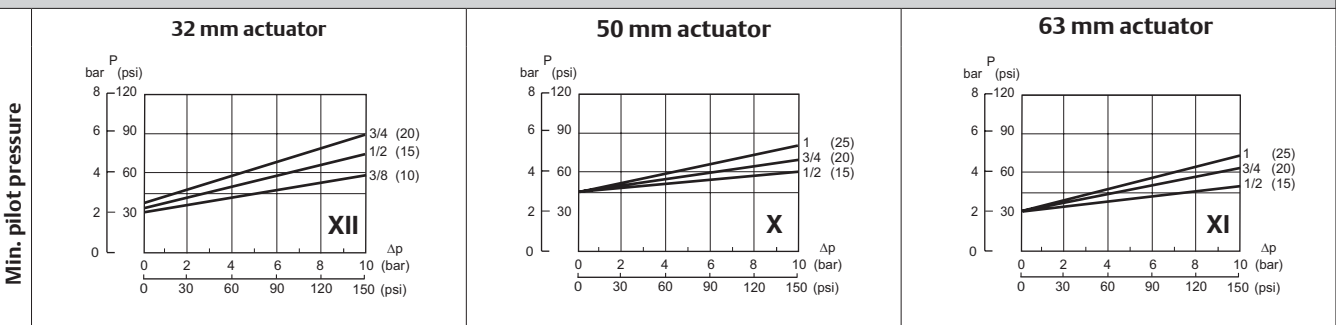

01534GB-2021/R01
Availability, design and specifications are subject to change without notice. All rights reserved.

ASCO™ Pneumatic Angle and Straight Seat Valves

Installation

- Valves can be mounted in any position without affecting operation
- Possibility to interchange actuators (sizes/functions) on the same body
- Adjustable actuator enables 360° access to pilot port
- Compatible with ASTM 1, 2 and 3 oils
- Pipe connections (G*) have standard combination thread according to ISO 228/1 and ISO 7/1
- Thread connection (NPTF) has a standard thread according to ANSI B 1.20.3
- Thread connection (Rc) has a standard thread according to ISO 7/1
- Pilot thread connection (G) or (NPT) has a standard thread according to ISO 228/1 or ANSI B1.20.1
- Installation/maintenance instructions in multiple languages are available on our website

Choice of options and accessories

Options	NC	NO	NC	-	Actuator diameter compatibility (mm)			
	Fluid entry under the disc	Fluid entry under the disc	Fluid entry above the disc	Bistable function	32	50	63	90
	AT0	•	•	•	•	•	•	•
AT1	•	•	•	•	•	•	•	•

When a combination of several options are selected (using the product configurator on our website) you will be provided with a specific combination code

ATEX/IECEX

- 2/2 valves NC/NO designed for use in potentially explosive atmospheres in accordance with ATEX-Directive 2014/34/EU
- EC type examination certificate no.: **LCIE 20 ATEX 3037 X**
- IECEX Certificate of Conformity no.: **IECEX LCIE 20.0025X**
- Compliance with the Essential Health and Safety Requirements of the ATEX Directive has been assured by compliance with European Standards EN ISO 80079-36 and EN ISO 80079-37
- Recommended for applications in the chemical, oil, gas and paint coating industries etc.

ATEX-Directive 2014/34/EU, category 1

Classification (zones) Category 1						
Dusts			Gas			Safety code
IIIA	IIIB	IIIC	IIA	IIIB	IIC	
Zone 20			Zone 0			Ⓢ II 1G Ex h IIC T* Ga Ⓢ II 1D Ex h IIIC T*°C Da

1GD		Metallic actuator	
T*°C	T*	Ts amb	T fluid
300°C	T2	80°C	220°C
200°C	T3	80°C	149°C
135°C	T4	80°C	97°C
100°C	T5	70°C	69°C
85°C	T6	60°C	57°C

ATEX-Directive 2014/34/EU, category 2

Classification (zones) Category 2						
Dusts			Gas			Safety code
IIIA	IIIB	IIIC	IIA	IIIB	IIC	
Zone 21			Zone 1			Ⓢ II 2G Ex h IIC T* Gb X Ⓢ II 2D Ex h IIIC T*°C Db X

2GD		Metallic actuator	
T*°C	T*	Ts amb	T fluid
300°C	T2	80°C	220°C
200°C	T3	80°C	184°C
135°C	T4	80°C	119°C
100°C	T5	70°C	80°C
85°C	T6	60°C	60°C

T*°C = Surface temperature
 T* = Temperature class
 Ts amb = Ambient temperature
 T fluid = Fluid temperature









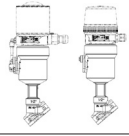

01534GB-2021/R01
Availability, design and specifications are subject to change without notice. All rights reserved.

ASCO

Visit our website at Emerson.com/ASCO

13

Choice of options and accessories

Options	NC	NO	NC	-	Actuator diameter compatibility (mm)				
	Fluid entry under the disc	Fluid entry under the disc	Fluid entry above the disc	Bistable function	32	50	63	90	
PFB	•	•	•	-	•	•	•	•	 Prepared for signaling box mounting
-	•	•	•	-	-	•	•	•	 See the dedicated catalogue pages • The signaling box fits on compatible actuators to indicate whether the valve is open or closed
-	•	•	•	-	•	•	•	•	 See the dedicated catalogue pages • Signaling unit with reed switch or magneto-resistive (MR) detectors for compatible actuators
WOB	•	•	•	•	•	•	•	•	 Without Body
02S	•	•	•	•	•	•	•	•	 Oxygen service • Special grease and cleaning • Pressure limited to 15 bar/temperature limited to +60°C
see page 8	•	•	•	•	-	•	•	•	 Adapter plate for NAMUR pad-mount pilot • Adaptable sur actionneurs 63 mm, 90 mm et 125 mm • Stainless steel AISI 316L • Solenoid pilot valves, series 551, 3/2 NC: - Aluminum body, catalog number SCG551A001 - AISI 316L stainless steel body, catalog number SCG551A409
STL	•	-	•	-	-	•	•	•	 Stroke limiter for opening
TC6	•	•	•	•	•	•	•	•	Test tightness class VI (FCI 70-2)
VAC	•	•	-	-	•	•	•	•	 Industrial vacuum 10 ⁻³ mbar (FPM disc)
M31	•	•	•	•	•	•	•	•	Valve body material composition certificate 3.1
FB0	•	•	•	•	•	•	•	•	 EC 1935-2004 and FDA CFR 21 material
FEM	•	•	•	•	-	-	•	•	Fugitive emission class BH according to ISO 15848-1
327	•	•	•	-	-	-	•	•	 Adaptation for pilot 327 (1/4", basic flow) See dedicated pilot catalog pages
WSP	•	•	•	-	•	•	•	•	PTFE wiper seal (for filtered / cleaned medium)
WSF	•	•	•	-	•	•	•	•	FPM piston seal
P16	•	-	-	-	-	•	•	•	PS > 16 bar (240 psi)

• Available feature

- Not available

Choice of pilots

(For information about pilots, please consult the dedicated catalog pages)

When a combination of several options are selected (using the product configurator on our website) you will be provided with a specific combination code

ASCO™ Pneumatic Angle and Straight Seat Valves

Series
290

Dimensions mm (inches), Weight kg (Lbs)

Configurator - CAD Files



TYPE 01
32 mm actuator / Angle seat valve
Fluid entry:
under the disc at 2
above the disc at 1

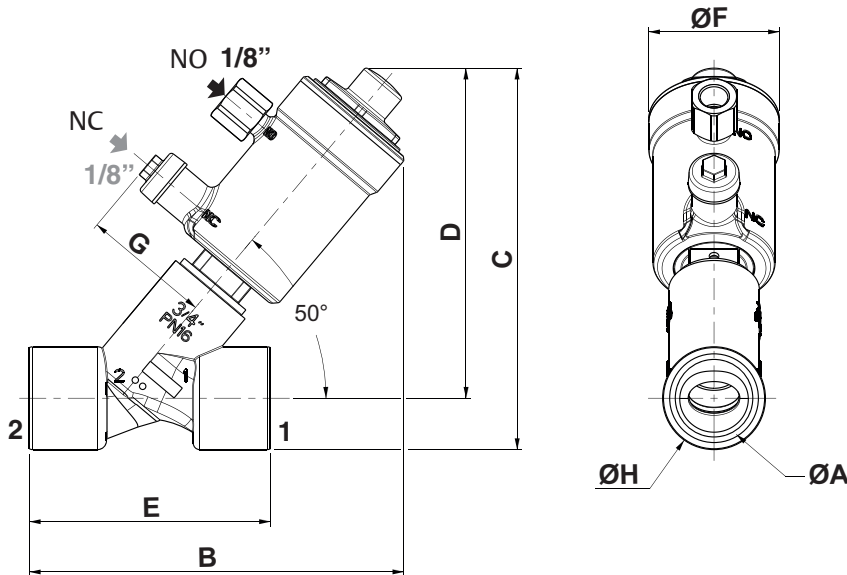

NC
entry
under the disc at 2

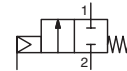

NO
entry
under the disc at 2

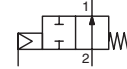

NC
entry
above the disc at 1

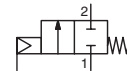

Bistable
entry under the
disc at 2

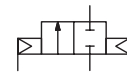

2 x 1/8"
orifices for piloting

Type	Actuator diameter	ØA	B	C	D	E	ØF	G	ØH	Weight ⁽¹⁾	
01	32 mm	G* 3/8" mm	102	107.5	96	55	41	40	24	0.6	kg
		NPT 3/8" (in)	4.016	4.232	3.780	2.165	1.614	1.575	0.945	1.2	(Lbs)
		G* 1/2" mm	108.5	111.5	98	65	41	40	27.5	0.6	kg
		NPT 1/2" (in)	4.272	4.390	3.858	2.559	1.614	1.575	1.083	1.3	(Lbs)
		G* 3/4" mm	116.5	119	103	75	41	40	32	0.7	kg
		NPT 3/4" (in)	4.587	4.685	4.055	2.953	1.614	1.575	1.260	1.5	(Lbs)

⁽¹⁾ Weight of valve without pilot.
For solenoid pilot valve. see dedicated catalog pages.

01534GB-2021/R01
Availability, design and specifications are subject to change without notice. All rights reserved.

Dimensions mm (inches), Weight kg (Lbs)

Configurator - CAD Files



TYPE 02
50 mm actuator / Angle seat valve
Fluid entry:
under the disc at 2
above the disc at 1

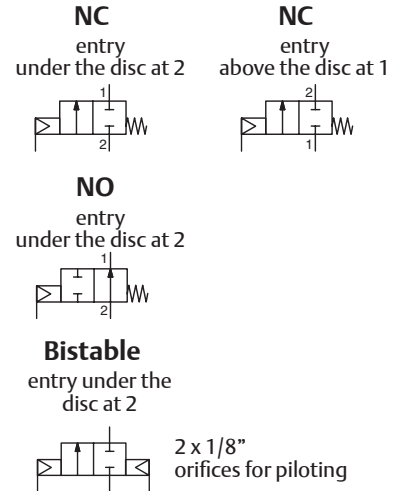
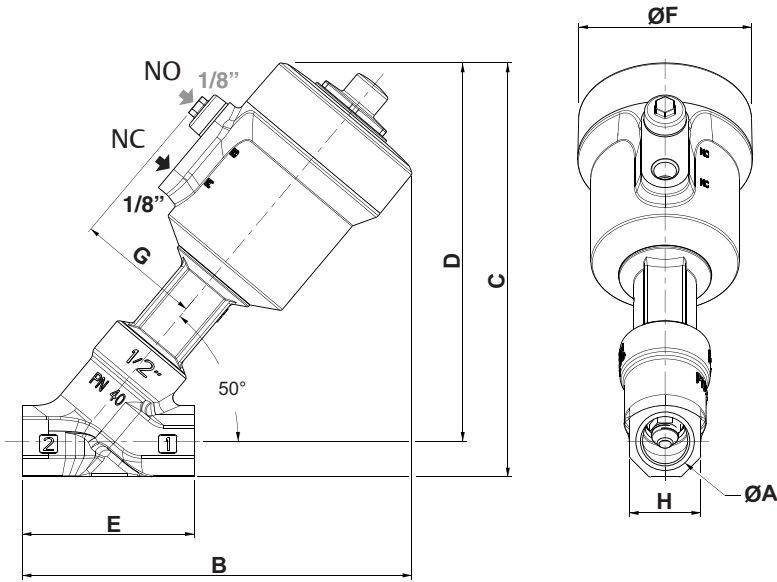

NAMUR plate
(NC / NO)

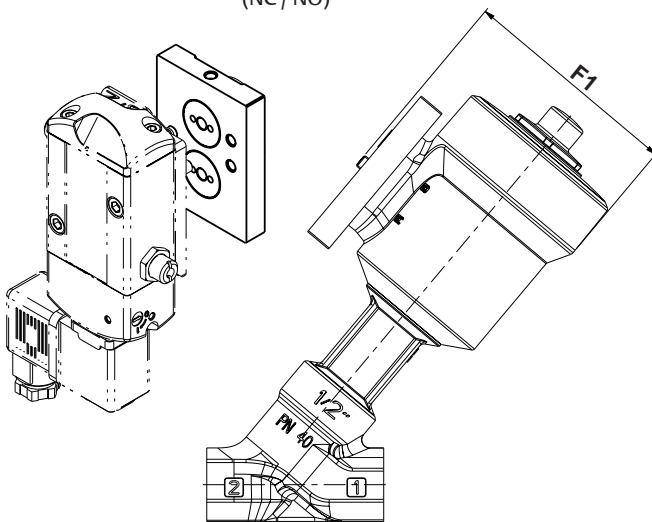

Type	Actuator diameter	ØA		B	C	D	E	ØF	F1	G	H	Weight (1)	
02	50 mm	G* 1/2"	mm	147	156.5	143	65	65.5	82	47	27	1.3	kg
		NPTF 1/2"	(in)	5.787	6.161	5.630	2.559	2.579	3.228	1.850	1.063	2.8	(Lbs)
		G* 3/4"	mm	151.5	160	144	75	65.5	82	47	32	1.4	kg
		NPTF 3/4"	(in)	5.965	6.299	5.669	2.953	2.579	3.228	1.850	1.260	3.1	(Lbs)
		G* 1"	mm	161	172.5	152	90	65.5	82	47	41	1.7	kg
		NPTF 1"	(in)	6.339	6.791	5.984	3.543	2.579	3.228	1.850	1.614	3.8	(Lbs)

(1) Weight of valve without pilot.
For solenoid pilot valve, see dedicated catalog pages.

ASCO™ Pneumatic Angle and Straight Seat Valves

Dimensions mm (inches), Weight kg (Lbs) 

Configurator - CAD Files



TYPE 02
50 mm actuator / Straight seat valve
Fluid entry:
under the disc at 2
above the disc at 1

NC
entry
under the disc at 2

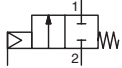

NO
entry
under the disc at 2

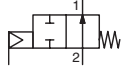

NC
entry
above the disc at 1

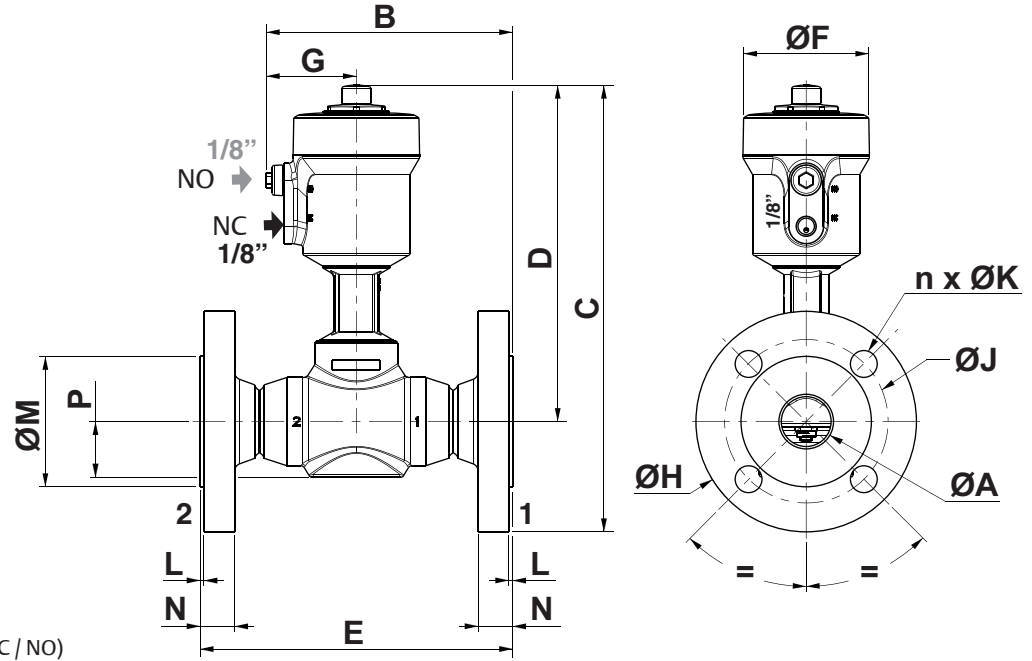
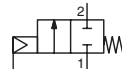

NAMUR plate (NC / NO)

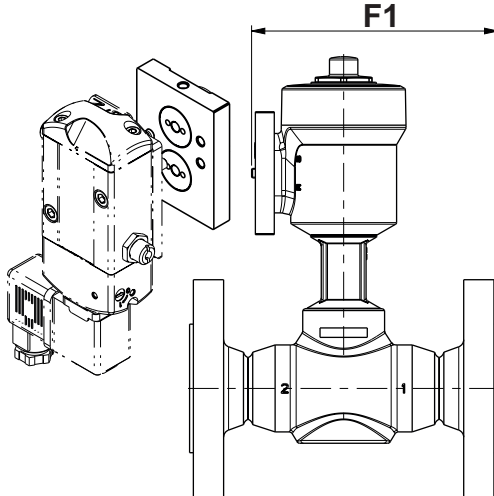

Type	Actuator diameter	DN	ØA	B	C		D	E	ØF	F1	G	ØH		ØJ			
					ISO	ANSI						ISO	ANSI	ISO	ANSI		
02	50 mm	15	mm	17.3	112	215.5	213	168	130	65.5	114	47	95	90	65	60.3	
			(in)	0.681	4.409	8.484	8.386	6.614	5.118	2.579	4.488	1.850	3.740	3.543	2.559	2.374	
			mm	22.3	122	220	217.5	167.5	150	65.5	124	47	105	100	75	69.9	
			(in)	0.878	4.803	8.661	8.563	6.594	5.906	2.579	4.882	1.850	4.134	3.937	2.953	2.752	
			mm	28.5	127	233	230.5	175.5	160	65.5	129	47	115	110	85	79.4	
			(in)	1.122	5.000	9.173	9.075	6.909	6.299	2.579	5.079	1.850	4.528	4.331	3.346	3.126	
		20	50 mm	DN	ØA	n x ØK		L		M		N		p	Weight ⁽¹⁾		
						ISO	ANSI	ISO	ANSI	ISO	ANSI	ISO	ANSI		ISO	ANSI	
				mm	17.3	4 x 14	4 x 16	2	1.5	45	34.9	16	13.2	19.8	2.9	2.5	kg
				(in)	0.681	4 x 0.551	4 x 0.630	0.079	0.059	1.772	1.374	0.630	0.520	0.778	6.5	5.6	(Lbs)
				mm	22.3	4 x 14	4 x 16	2	1.5	58	42.9	18	13.2	23	3.8	3.1	kg
				(in)	0.878	4 x 0.551	4 x 0.630	0.079	0.059	2.283	1.689	0.709	0.520	0.906	8.4	6.8	(Lbs)
25	50 mm	DN	ØA	n x ØK		L		M		N		p	Weight ⁽¹⁾				
				ISO	ANSI	ISO	ANSI	ISO	ANSI	ISO	ANSI		ISO	ANSI			
mm	28.5	4 x 14	4 x 16	2	1.5	68	50.8	18	14.2	29	4.6	3.9	kg				
(in)	1.122	4 x 0.551	4 x 0.630	0.079	0.059	2.677	2.000	0.709	0.559	1.142	10.1	8.5	(Lbs)				

⁽¹⁾ Weight of valve without pilot.

For solenoid pilot valve. see dedicated catalog pages.

01534GB-2021/R01
Availability, design and specifications are subject to change without notice. All rights reserved.

Dimensions mm (inches), Weight kg (Lbs)

Configurator - CAD Files



TYPE 03
63 mm actuator / Angle seat valve
Fluid entry:
under the disc at 2
above the disc at 1

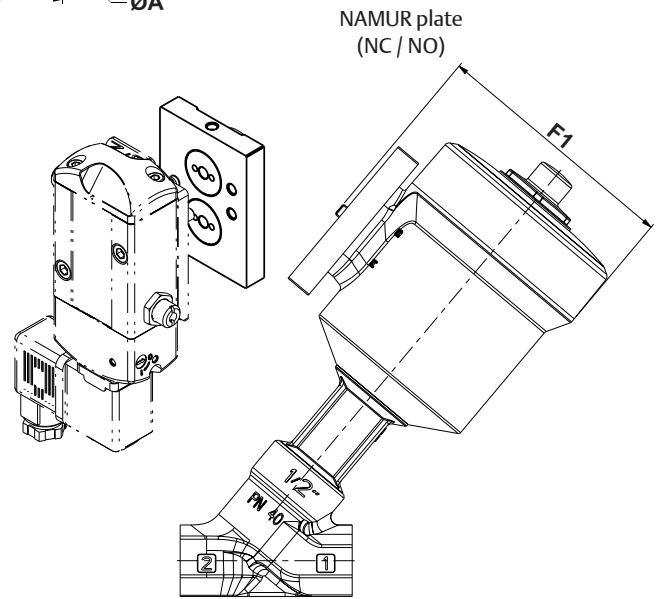
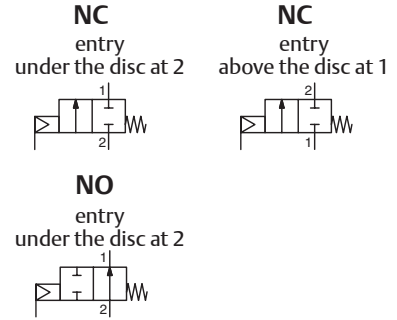
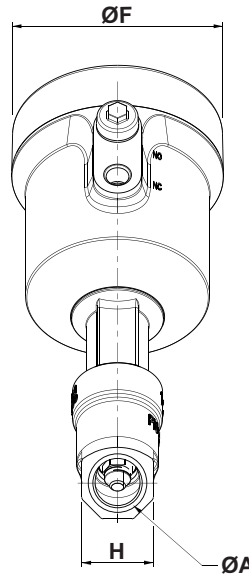
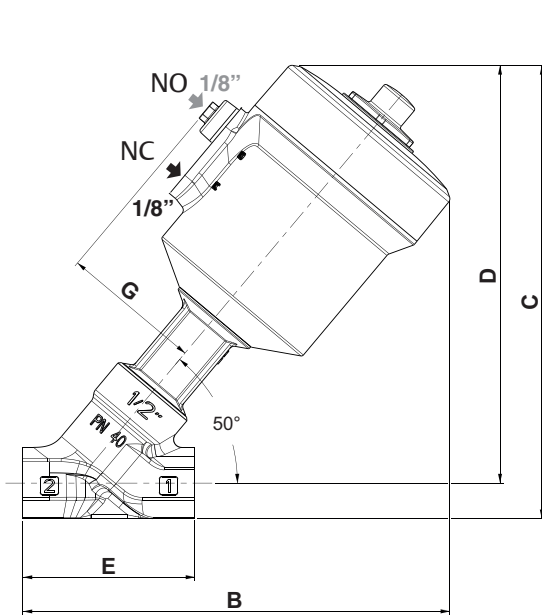

Type	Actuator diameter	ØA		B	C	D	E	ØF	F1	G	H	Weight (1)	
03	63 mm	G* 1/2"	mm	161.5	171.5	158	65	79.5	95	53	27	1.8	kg
		NPTF 1/2"	(in)	6.358	6.752	6.220	2.559	3.130	3.740	2.087	1.063	4.0	(Lbs)
		G* 3/4"	mm	165.5	175	159	75	79.5	95	53	32	1.9	kg
		NPTF 3/4"	(in)	6.516	6.890	6.260	2.953	3.130	3.740	2.087	1.260	4.2	(Lbs)
		G* 1"	mm	175	187	167	90	79.5	95	53	41	2.2	kg
		NPTF 1"	(in)	6.890	7.362	6.575	3.543	3.130	3.740	2.087	1.614	4.9	(Lbs)
		G* 1 1/4"	mm	195.5	203.5	178.5	110	79.5	95	53	50	2.6	kg
		NPTF 1 1/4"	(in)	7.697	8.012	7.028	4.331	3.130	3.740	2.087	1.969	5.7	(Lbs)
		G* 1 1/2"	mm	195	210.5	180.5	120	79.5	95	53	60	3.2	kg
		NPTF 1 1/2"	(in)	7.677	8.287	7.106	4.724	3.130	3.740	2.087	2.362	7.1	(Lbs)
		G* 2"	mm	218.5	222.5	187.5	150	79.5	95	53	70	4	kg
		NPTF 2"	(in)	8.602	8.760	7.382	5.906	3.130	3.740	2.087	2.756	8.8	(Lbs)

(1) Weight of valve without pilot.
For solenoid pilot valve, see dedicated catalog pages.

ASCO™ Pneumatic Angle and Straight Seat Valves

Dimensions mm (inches), Weight kg (Lbs)

Configurator - CAD Files

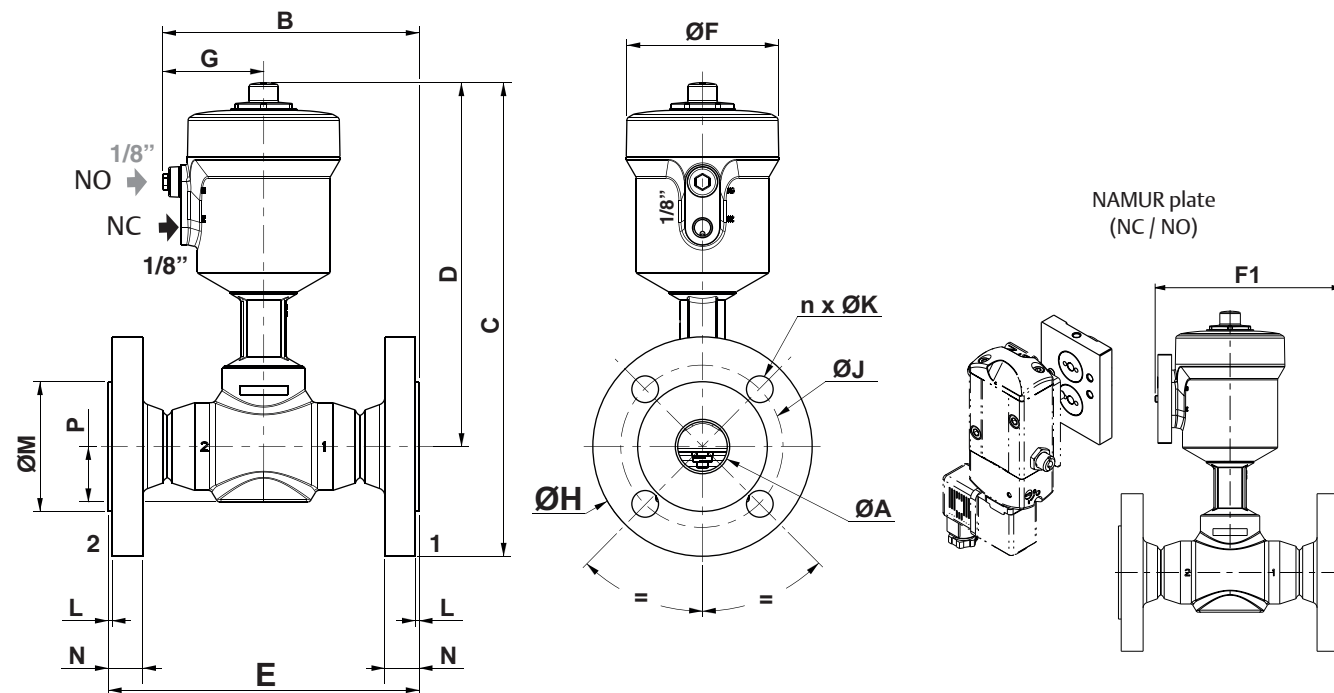
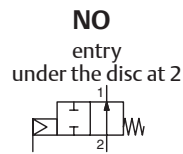
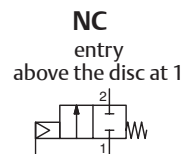
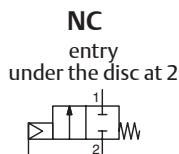
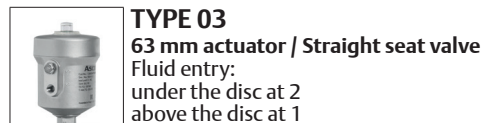

Type	Actuator diameter	DN	ØA	B	C		D	E	ØF	F1	G	ØH		ØJ				
					ISO	ANSI						ISO	ANSI	ISO	ANSI			
03	63 mm	15	mm	17.3	118	231	228.5	183.5	130	79.5	120	53	95	90	65	60.3		
			(in)	0.681	4.646	9.094	8.996	7.224	5.118	3.130	4.724	2.087	3.740	3.543	2.559	2.374		
		20	mm	22.3	128	235	232.5	182.5	150	79.5	130	53	105	100	75	69.9		
			(in)	0.878	5.039	9.252	9.154	7.185	5.906	3.130	5.118	2.087	4.134	3.937	2.953	2.752		
		25	mm	28.5	133	248.5	246	191	160	79.5	135	53	115	110	85	79.4		
			(in)	1.122	5.236	9.783	9.685	7.520	6.299	3.130	5.315	2.087	4.528	4.331	3.346	3.126		
		32	mm	37.2	143	278	265.5	208	180	79.5	145	53	140	115	100	88.9		
			(in)	1.465	5.630	10.945	10.453	8.189	7.087	3.130	5.709	2.087	5.512	4.528	3.937	3.500		
		40	mm	43.1	153	280	267.5	205	200	79.5	155	53	150	125	110	98.4		
			(in)	1.697	6.024	11.024	10.531	8.071	7.874	3.130	6.102	2.087	5.906	4.921	4.331	3.874		
		50	mm	54.5	168	298	290.5	215.5	230	79.5	170	53	165	150	125	120.7		
			(in)	2.146	6.614	11.732	11.437	8.484	9.055	3.130	6.693	2.087	6.496	5.906	4.921	4.752		
		03	63 mm	15	mm	17.3	4 x 14	4 x 16	2	1.5	45	34.9	16	13.2	19.8	3.5	3.1	kg
					(in)	0.681	4 x 0.551	4 x 0.630	0.079	0.059	1.772	1.374	0.630	0.520	0.778	7.6	6.7	(Lbs)
				20	mm	22.3	4 x 14	4 x 16	2	1.5	58	42.9	18	13.2	23	4.3	3.6	kg
					(in)	0.878	4 x 0.551	4 x 0.630	0.079	0.059	2.283	1.689	0.709	0.520	0.906	9.5	7.9	(Lbs)
				25	mm	28.5	4 x 14	4 x 16	2	1.5	68	50.8	18	14.2	29	5.0	4.3	kg
					(in)	1.122	4 x 0.551	4 x 0.630	0.079	0.059	2.677	2.000	0.709	0.559	1.142	11.1	9.5	(Lbs)
32	mm			37.2	4 x 18	4 x 16	2	1.5	78	63.5	18	15.8	32.5	6.9	5.4	kg		
	(in)			1.465	4 x 0.709	4 x 0.630	0.079	0.059	3.071	2.500	0.709	0.622	1.280	15.1	11.9	(Lbs)		
40	mm			43.1	4 x 18	4 x 16	3	1.5	88	73	18	17.4	36.9	8.0	6.7	kg		
	(in)			1.697	4 x 0.709	4 x 0.630	0.118	0.059	3.465	2.874	0.709	0.685	1.451	17.5	14.8	(Lbs)		
50	mm			54.5	4 x 18	4 x 19.1	3	1.5	102	92.1	20	19	42.5	10.7	9.7	kg		
	(in)			2.146	4 x 0.709	4 x 0.752	0.118	0.059	4.016	3.626	0.787	0.748	1.673	23.6	21.3	(Lbs)		

⁽¹⁾ Weight of valve without pilot.
For solenoid pilot valve. see dedicated catalog pages.

01534GB-2021/R01 Availability, design and specifications are subject to change without notice. All rights reserved.

Dimensions mm (inches), Weight kg (Lbs)

Configurator - CAD Files



TYPE 04
90 mm actuator / Angle seat valve
Fluid entry:
under the disc at 2
above the disc at 1

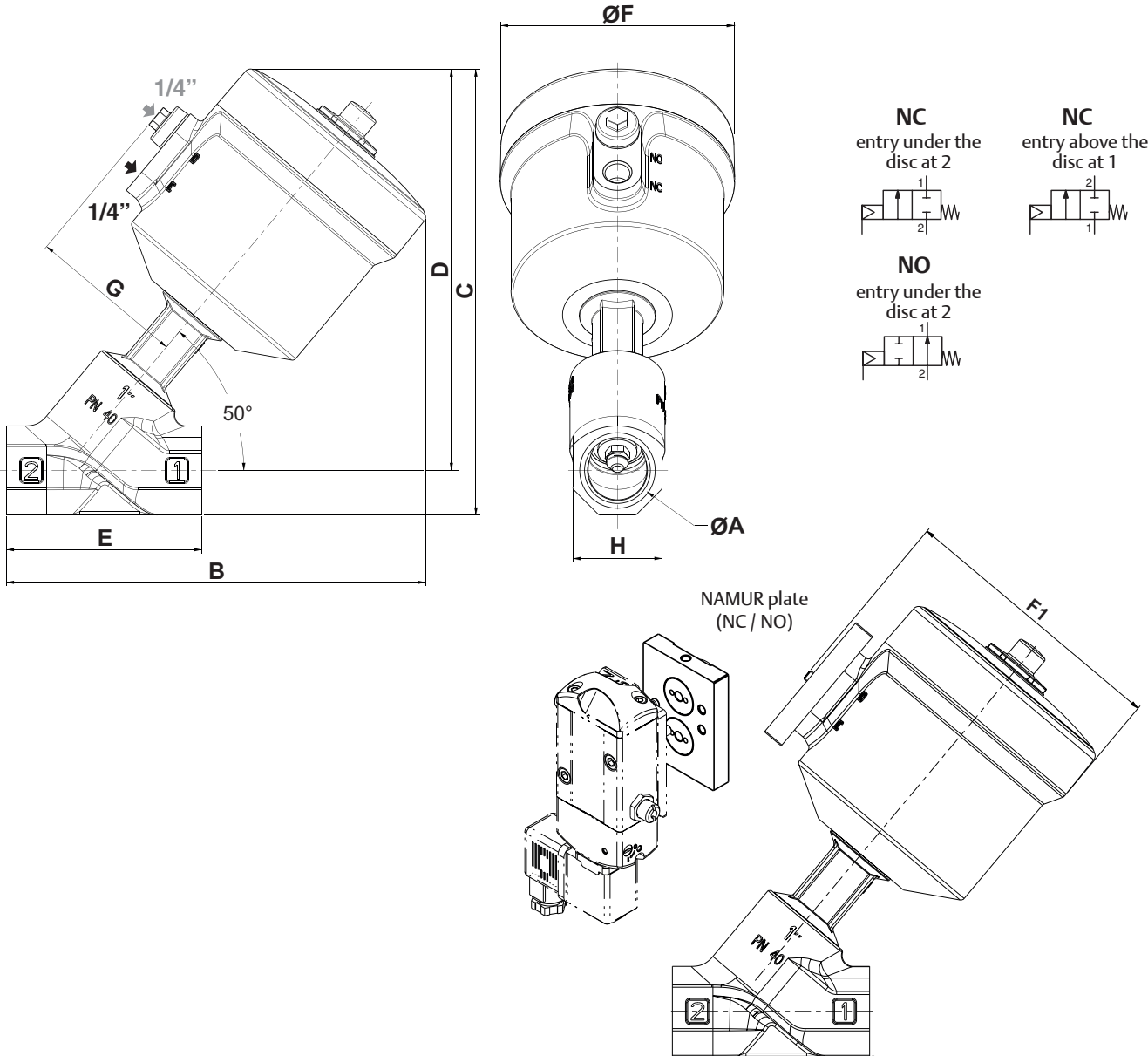

Type	Actuator diameter	ØA		B	C	D	E	ØF	F1	G	H	Weight ⁽¹⁾	
04	90 mm	G* 1"	mm	193	205.5	185	90	108	126	72	41	3.3	kg
		NPTF 1"	(in)	7.598	8.091	7.283	3.543	4.252	4.961	2.835	1.614	7.2	(Lbs)
		G* 1 1/4"	mm	214	221.5	196.5	110	108	126	72	50	3.7	kg
		NPTF 1 1/4"	(in)	8.425	8.720	7.736	4.331	4.252	4.961	2.835	1.969	8.1	(Lbs)
		G* 1 1/2"	mm	213.5	228.5	198.5	120	108	126	72	60	4.3	kg
		NPTF 1 1/2"	(in)	8.406	8.996	7.815	4.724	4.252	4.961	2.835	2.362	9.4	(Lbs)
		G* 2"	mm	237	240.5	205.5	150	108	126	72	70	5	kg
		NPTF 2"	(in)	9.331	9.469	8.091	5.906	4.252	4.961	2.835	2.756	11.2	(Lbs)
		G* 2 1/2"	mm	265.5	261.5	218	190	108	126	72	87	7.2	kg
		NPTF 2 1/2"	(in)	10.453	10.295	8.583	7.480	4.252	4.961	2.835	3.425	15.8	(Lbs)

⁽¹⁾ Weight of valve without pilot.
For solenoid pilot valve, see dedicated catalog pages.

Dimensions mm (inches), Weight kg (Lbs)

Configurator - CAD Files



TYPE 04
90 mm actuator / Straight seat valve
Fluid entry:
under the disc at 2
above the disc at 1

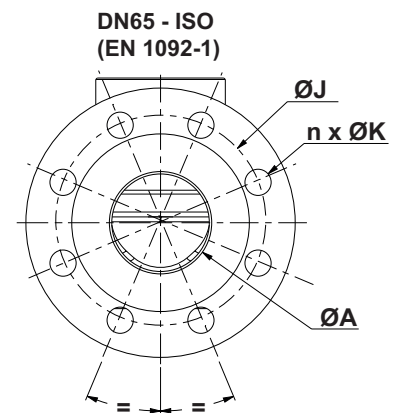
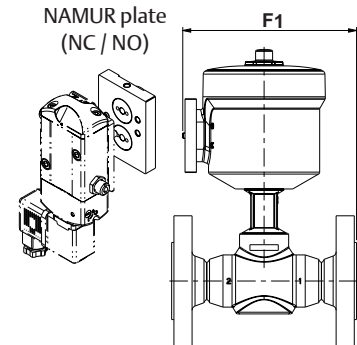
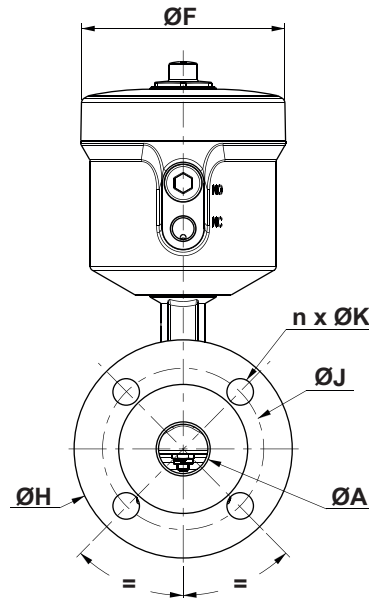
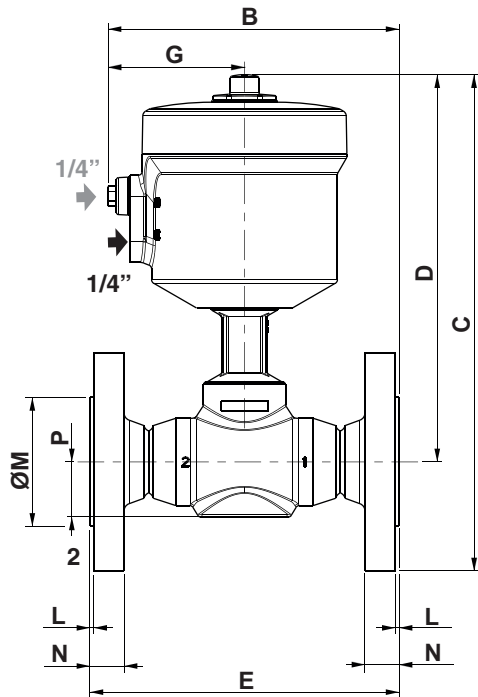

Type	Actuator diameter	DN	ØA	B	C		D	E	ØF	F1	G	ØH		ØJ				
					ISO	ANSI						ISO	ANSI	ISO	ANSI			
04	90 mm	25	mm	28.5	152	262	259.5	204.5	160	108	152	72	115	110	85	79.4		
			(in)	1.122	5.984	10.315	10.217	8.051	6.299	4.252	5.984	2.835	4.528	4.331	3.346	3.126		
		32	mm	37.2	162	291	278.5	221	180	108	162	72	140	115	100	88.9		
			(in)	1.465	6.378	11.457	10.965	8.701	7.087	4.252	6.378	2.835	5.512	4.528	3.937	3.500		
		40	mm	43.1	172	293.5	281	218.5	200	108	172	72	150	125	110	98.4		
			(in)	1.697	6.772	11.555	11.063	8.602	7.874	4.252	6.772	2.835	5.906	4.921	4.331	3.874		
		50	mm	54.5	187	311.5	304	229	230	108	187	72	165	150	125	120.7		
			(in)	2.146	7.362	12.264	11.969	9.016	9.055	4.252	7.362	2.835	6.496	5.906	4.921	4.752		
		65	mm	70.3	217	346.5	344	254	290	108	217	72	185	180	145	139.7		
			(in)	2.768	8.543	13.642	13.543	10.000	11.417	4.252	8.543	2.835	7.283	7.087	5.709	5.500		
		04	90 mm	25	mm	28.5	4 x 14	4 x 16	2	1.5	68	50.8	18	14.2	29	6.1	5.4	kg
					(in)	1.122	4 x 0.551	4 x 0.630	0.079	0.059	2.677	2.000	0.709	0.559	1.142	13.4	11.9	(Lbs)
32	mm			37.2	4 x 18	4 x 16	2	1.5	78	63.5	18	15.8	32.5	8	6.5	kg		
	(in)			1.465	4 x 0.709	4 x 0.630	0.079	0.059	3.071	2.500	0.709	0.622	1.280	17.6	14.4	(Lbs)		
40	mm			43.1	4 x 18	4 x 16	3	1.5	88	73	18	17.4	36.9	9	7.8	kg		
	(in)			1.697	4 x 0.709	4 x 0.630	0.118	0.059	3.465	2.874	0.709	0.685	1.451	19.8	17.1	(Lbs)		
50	mm			54.5	4 x 18	4 x 19.1	3	1.5	102	92.1	20	19	42.5	11.7	10.7	kg		
	(in)			2.146	4 x 0.709	4 x 0.752	0.118	0.059	4.016	3.626	0.787	0.748	1.673	25.8	23.5	(Lbs)		
65	mm			70.3	8 x 18	4 x 19.1	3	1.5	122	104.8	22	22.2	59	16.4	16.6	kg		
	(in)			2.768	8 x 0.709	4 x 0.752	0.118	0.059	4.803	4.126	0.866	0.874	2.323	36.2	36.5	(Lbs)		

⁽¹⁾ Weight of valve without pilot.

For solenoid pilot valve, see dedicated catalog pages.

01534GB-2021/R01
Availability, design and specifications are subject to change without notice. All rights reserved.

